



HYBRIDFLUSH® TOP MOUNT

AUTOMATIC CONCEALED WATER CLOSET FLUSHOMETER

Model
AEF-801-CCT-16

Description

Hardwired, Sensor Operated HYBRIDFLUSH® Top Mount Concealed Water Closet (Toilet) Flushometer for Floor Mounted or Wall Hung Top or Rear Spud Bowls.

Flush Cycle

Model AEF-801-CCT-16 (1.6 gpf/6.0 Lpf)

Features

- Patented BRV® and Gear Motor Drive
- Wall Mounted Plate with Sensor
- Hands Free Infrared Sensor Activation
- Vandal and Water Resistant Design
- Chrome Plated All Metal Housing
- Quiet Operation
- Electronic Flush Button
- Operates on 6-Volt DC Power (Transformer Sold Separately)
- Adjustable Sensor Distance
- Optional Three (3) Second Flush Delay Mode
- Optional 24-Hour Flush Mode
- Uses Proprietary Silicone Diaphragm with Filtered Bypass
- 1" I.P.S. Angle Stop
- Adjustable Tailpiece
- High Back Pressure Vacuum Breaker with Single Piece Hex Coupling Nut
- Spud Coupling and Flange for 1 1/2" Top or Rear Spud
- Sweat Solder Kit and Wall Flange with Set Screw
- Low Consumption For Water Conservation

*AEF-801-CCT units include a Valve Body, Supply Stop and Vacuum Breaker.

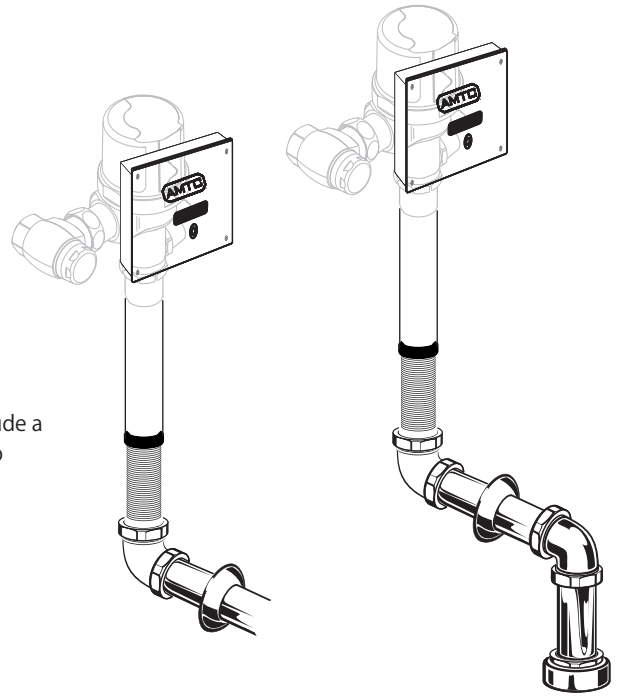

The HYBRIDFLUSH® Advantage

The HYBRIDFLUSH® is a revolutionary full-featured automatic flushometer. The HYBRIDFLUSH® incorporates a unique patented mechanism that allows for unsurpassed reliability. The HYBRIDFLUSH® by Advanced Modern Technologies Corporation is the most efficient, economical, and complete automatic flush valve system on the market.

Code Compliance (Listed By IAPMO)

- ASSE 1037-2015
- ASME A112.1035-2015
- CSA B125.37-15

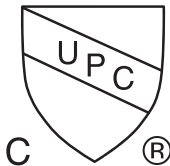

Warranty
5 Years



Accessories (Add suffix to model number for accessories)

AMTCTRANS6VDC - 6-Volt AC/DC Transformer

For Finish Variations Please Consult Factory

Architect/Engineer Approval

Job Name	_____
Date	_____
Model Specified	_____
Quantity	_____
Variations Specified	_____
Customer/Wholesaler	_____
Contractor	_____
Architect	_____

The information contained in this document is subject to change without notice.
Revision (05/18)



HYBRIDFLUSH® TOP MOUNT

AUTOMATIC CONCEALED WATER CLOSET FLUSHOMETER

Model
AEF-801-CCT-16

Specifications:

Operation:	Automatic
Outer Casing:	Standard-Chrome Metal
Operating Water Pressure:	15 PSI - 100 PSI
Sensor Type:	Infrared
Power Type:	6-Volt DC Power
Arming Delay:	5 Seconds
Flush Delay:	3 Seconds
Sensing Range:	18" (45cm) - 30" (75cm) Adjustable
Ghost Flush:	Once Every 24 Hours From Last Flush
Sensor Angle:	Fixed Angle
Flush Cycle:	Specified by Model
Model AEF-801-CCT-16	1.6 gpf/6.0 Lpf
Flush Mode:	After Every Use
Manual Override:	Electronic Flush Button

Application:

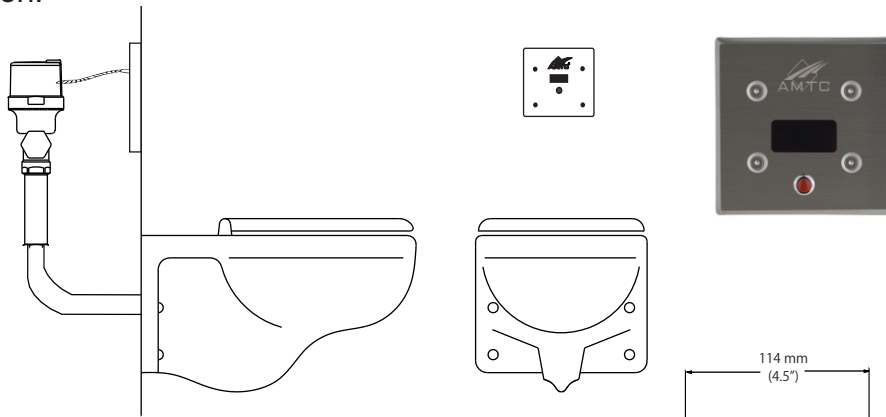

Dimensions:

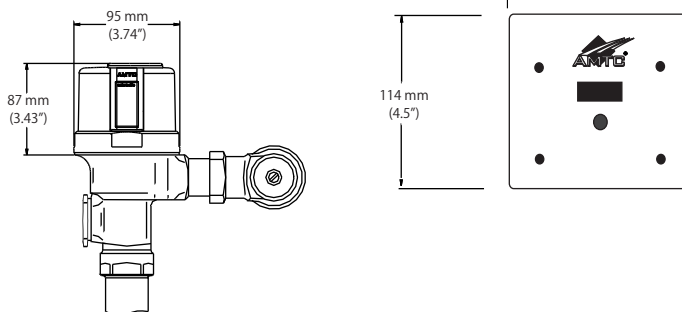

Exploded View:

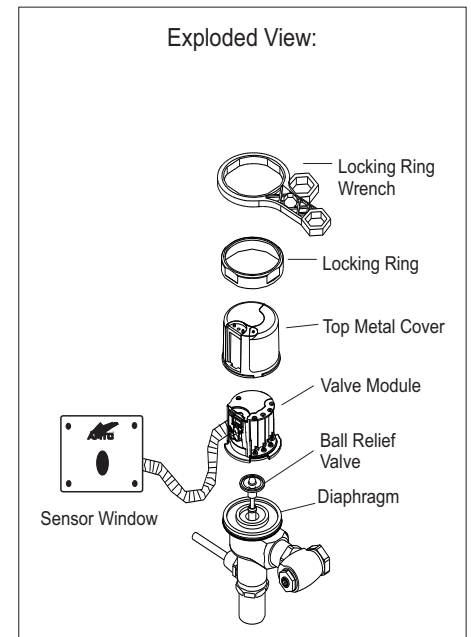

Advanced Modern Technologies Corporation • 19800 Nordhoff Place • Chatsworth, CA 91311
Tel: (818) 883-2682 • Toll Free: (800) 874-7822 • Fax: (818) 883-2620 • www.amtcorporation.com